

Buying the Proper Proximity Sensor

Not All Proximity Sensors Are Created Equal...

Namco makes two grades of proximity sensors:

- Tough - Our "Standard Industrial Grade" line
- Incredibly Tough - Our WFI Automotive-Grade Line

Most industrial applications require a pretty rugged sensor; for example, a packaging machine or material handling application. For these jobs, Namco's Standard Industrial Grade products are well-suited. However, there are some applications where nothing but the most durable will do. For example, if you have lots of welding activity nearby, both physical and electronic characteristics must be upgraded.

To make sure you match your sensor selection to your application, call 1-800-NAMTECH.

Namco Standard Industrial Grade Sensor

Liquid polyurethane used as encapsulant.

Single LED - on with target present.

Thermoplastic sensing face.

Value priced.

No weld field immunity.

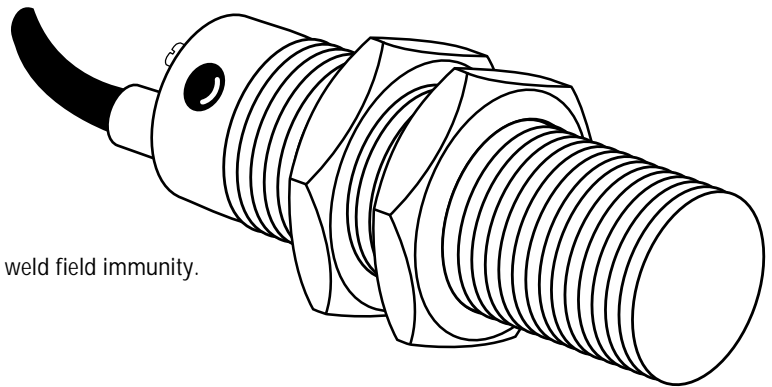

Housings of either thermoplastic or chrome plated brass.

Current-limit type short circuit protection on some models (as indicated in selector chart).



Namco Weld Field Immune (WFI) Sensor

Circuitry to accept a broad range of input voltages. Predictable, consistent electrical performance independent of input impedance and voltage.

Housing must withstand 300 pound step test and/or 250 pound cantilevered load test per UL 508.

Special epoxy encapsulants are mechanically strong while maintaining electrical insulative properties.

Meets UL 508 requirements. Connectors, cables, and sensor tested for strength, flammability, insulation, torque, and pull out.

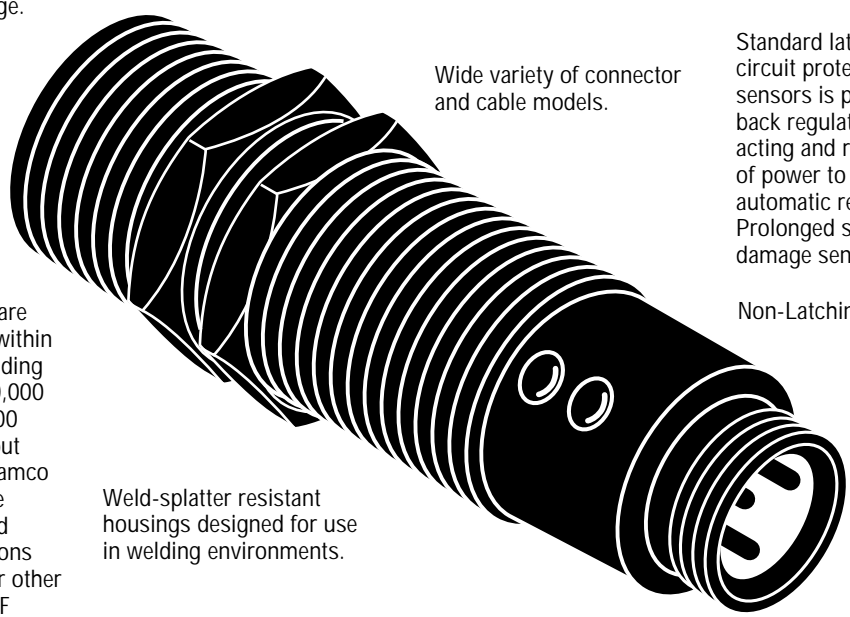

Wide variety of connector and cable models.

Standard latching short circuit protection in Namco sensors is patented fold-back regulator type; fast-acting and requires removal of power to prevent automatic restart. Prolonged shorts will not damage sensor electronics.

Non-Latching.

Namco WFI sensors are designed to operate within 1" of a resistance welding electrode carrying 20,000 Amperes RMS (45,000 Amperes peak) without changing state. All Namco WFI sensors pass the NEMA noise tests and exhibit no false turn-ons from walkie-talkies or other in-plant sources of RF Noise.

Weld-splatter resistant housings designed for use in welding environments.

Every Namco WFI sensor:
1) goes through 52 automatic testing steps;
2) is thermocycled between -20°C to +70°C;
3) is 100% functionally tested.

Two LED's: Green for "target sensed" and red for "power available" (AC/DC versions); Green for "power available" and amber for "target sensed" (DC versions).

Molded thermoset plastics for rectangular and extended range, hard coat for tubulars.



Namco Controls Corporation
Mayfield Village, OH 44143
(440) 460-1360 • FAX (440) 460-3800 • namcocontrols.com

For technical assistance, call 1-800-NAMTECH

Principles of Operation

Inductive

Proximity sensors are generally constructed with four main elements: (1) a coil and ferrite core assembly; (2) an oscillator; (3) a convertor/trigger circuit (detector) and; (4) an output device.

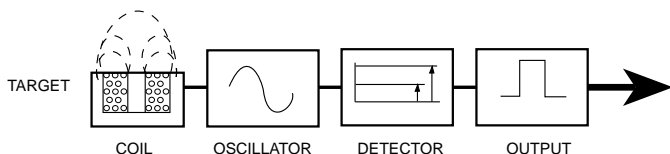

Figure 1

The oscillator creates a radio frequency field that is shaped and defined by the coil and core. As a target is placed in this field, eddy currents are set up in the surface of the target. The oscillator, being a limited power device, will lower its amplitude as the eddy currents are produced. The convertor/trigger circuit rectifies the AC sine wave signal to DC, compares the level against a preset reference, and actuates the sensor output if a target is present. Switching is clean, with none of the bounce of mechanical switches.

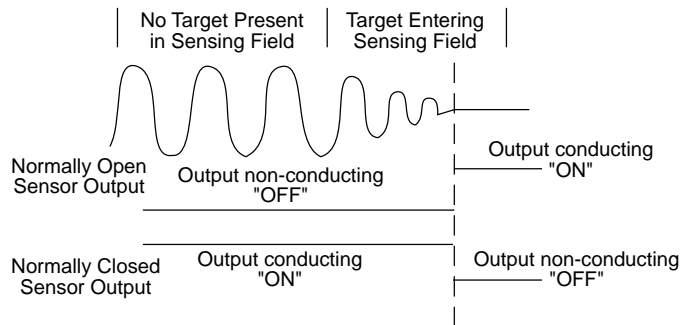

Figure 2

Capacitive

Essentially similar except that the coil is replaced by a sensing plate, and the oscillator is not running until the object to be detected is within range.

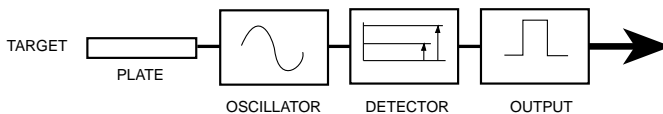

Figure 3

Capacitive sensors depend on the coupling between the sensing plate and earth ground. If a target is placed within range, the capacitance level will vary depending on target density, conductivity, and relative humidity. If the adjustment potentiometer is correctly set, the oscillator will be turned on when a target is within range.

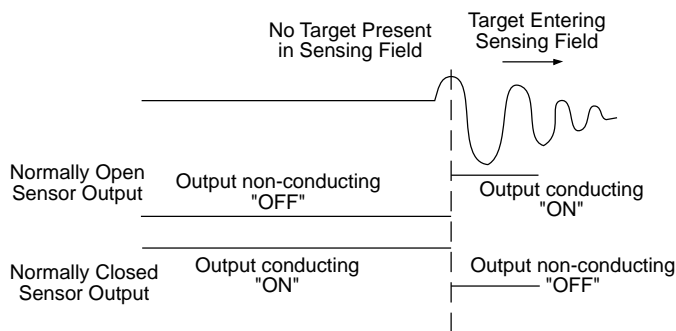

Figure 4

Important Note: Never use a metal body capacitive sensor in wet environments. Moisture between the sensing plate and the metal body will cause the sensor to "lock on." For wet environments, always use a plastic bodied sensor.

Inductive Sensor Selection

1. Target Identification

This is the most critical step in proper application of inductive and capacitive sensors. Most application problems stem from improper selection of a sensor for a particular target. This usually comes from a desire to "standardize" a design. Generally the following rules apply to all inductive sensors:

The sensor face should equal or be smaller than the target surface area. All manufacturers calibrate the range of a particular sensor with a "standard target." This standard target is always larger than the diameter of the sensor face. Although it is possible to sense targets smaller than the sensor face diameter, rated range cannot be achieved using a target that is smaller than the sensor face. The following changes in the sensing range will occur if the dimensions of the target are larger or smaller than the standard target specified.

Target size in %	150	125	100 (Standard Target)	75	50	25	12.5
Deviation from Sn in %	+10	+7	0	-7	-14	-27	-45

Figure 5

2. Air Gap Determination

When examining your application, remember that most shielded inductive sensors (Fig. 6) will have a maximum range that is approximately one third of the diameter of the sensing face.

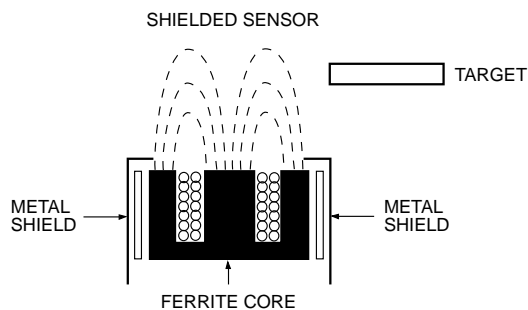

Figure 6

It is often necessary to allow a rather large air gap between the target and the sensor. When this is required, an unshielded sensor (Fig. 7) will be required. The unshielded sensor will generally have the plastic "nose" of the sensor projecting out of the metal barrel, or (plastic bodied types) it will not have a shielding ring around the core. These unshielded sensors will typically sense at ranges 3 to 50 percent greater than shielded types. A penalty is paid, however, as it is necessary to provide a metal-free area around the sensor that is much larger than the shielded types.

NONSHIELDED SENSOR

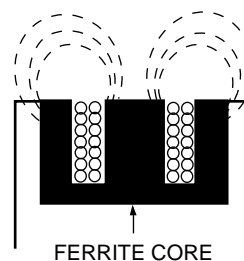

Figure 7

(See 3. Mounting Clearances)

Positioning of the sensor should allow the target to penetrate approximately 30% into the field to allow for manufacturing tolerances, resistance to vibration, and inaccuracies that are common to all initial start-ups.

When determining the air gap (sensing distance) required, it should be noted that an inductive sensor will produce its rated range only against a standard target of mild steel. Other materials will reduce the sensing range (SN) as follows:

- Mild Steel SN x 1.0
- Aluminum Foil SN x 1.0
- Stainless Steel SN x 0.85
- Brass SN x 0.5
- Copper SN x 0.46
- Aluminum SN x 0.4

Continued on next page. →



Namco Controls Corporation
Mayfield Village, OH 44143

(440) 460-1360 • FAX (440) 460-3800 • namcocontrols.com

For technical assistance, call 1-800-NAMTECH

Example: If a sensor with a 5mm sensing range is used to sense a standard target made of copper, the sensing range of the sensor is reduced as indicated below:

$$5\text{mm} (0.46) = 2.3\text{mm} (\text{maximum})$$

When mounting a sensor it is always preferred to position the target so that it "slides by" the sensor face. This type of mounting will ensure that the sensor face is not damaged by contact with the target. If your application dictates a "head on" approach, it is essential that the target does not use the sensor face as a physical stop. Failure to provide clearance in either the slide-by or head-on modes will result in damage to the sensor and possible failure of the device.

Hysteresis (Fig. 8) must be allowed for as the target must move far enough away from the sensing field so that the sensor cannot detect it. If a target is placed within the hysteresis band, vibration of the target can cause the switch to turn on and off rapidly ("chatter"). All sensor manufacturers build in a certain amount of hysteresis to minimize chatter.

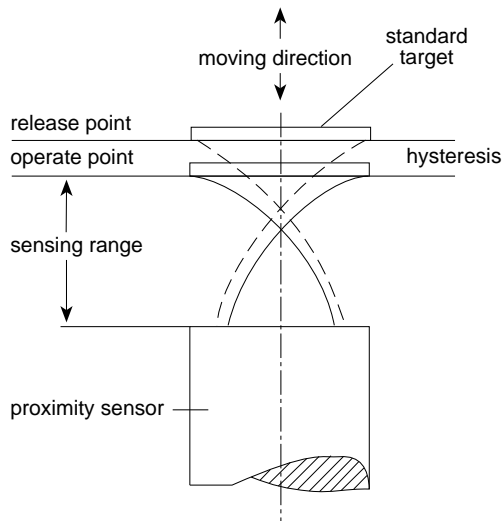
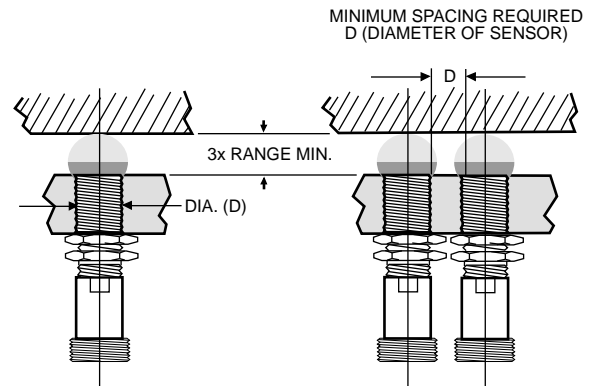

Figure 8

3. Mounting Clearances

Mounting of sensors should follow industry accepted practices as shown. Failure to properly position the sensor is the single largest cause of field problems.

SHIELDED SENSORS (FLUSH MOUNTABLE)



UNSHIELDED SENSORS REQUIRE METAL-FREE AREA

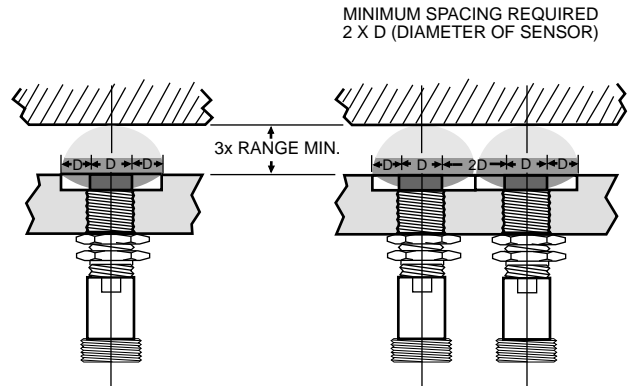

SENSORS MUST BE MOUNTED SUCH THAT SURROUNDING METAL IS NOT IN THE SENSING AREA.

OPPOSING SENSORS

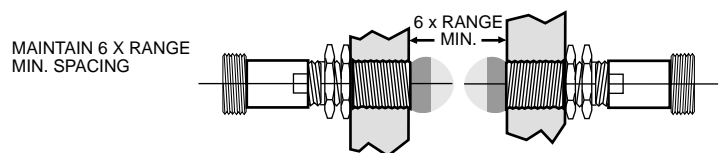

Figure 9

4. Housing Selection

After you have determined the target and air gap, it is then possible to select the style of housing for the application. Sensors are typically grouped according to range against a standard target. The most often used types are the metal barrel styles. These are great for general purpose uses but should not be used in areas where liquids are present. For wet environments, the all-plastic types are preferred. To determine your best specific type, consult the Enclosure Types below.

Various accessories are available for sealing, conduit, and mounting. Also, many sensors are available with quick disconnects. This is more expensive initially but can be justified if the sensor is placed on moving equipment where the cable is flexed often. The weak link then becomes the entry point of the cable to the housing. When failure occurs, it is necessary to replace the complete assembly because the cable failed. It's also easier to position the sensor mechanically, then complete the electrical wiring.

**Industrial Control Equipment - UL 508
Table 6.1 – Enclosure Designations**

Designation	Intended Use and Description	Designation	Intended Use and Description
1	Indoor use primarily to provide protection against contact with the enclosed equipment and against a limited amount of falling dirt.	4X	Either indoor or outdoor use to provide a degree of protection against falling rain, splashing water, and hose-directed water; undamaged by the formation of ice on the enclosure; resists corrosion.
2	Indoor use to provide a degree of protection against limited amounts of falling water and dirt.	6	Indoor or outdoor use to provide against the entry of water during temporary, limited submersion; undamaged by the formation of ice on the enclosure.
3	Outdoor use to provide a degree of protection against windblown dust and windblown rain; undamaged by the formation of ice on the enclosure.	6P	Indoor and outdoor use to provide a degree of protection against the entry of water during prolonged submersion at limited depths.
3R	Outdoor use to provide a degree of protection against falling rain; undamaged by the formation of ice on the enclosure.	11	Indoor use to provide by oil immersion a degree of protection of the enclosed equipment against the corrosion effects of corrosive liquids and gases.
3S	Outdoor use to provide a degree of protection against windblown dust, windblown rain, and sleet; external mechanisms remain operable while ice laden.	12, 12K	Indoor use to provide a degree of protection against dust, dirt, fiber flyings, dripping water, and external condensation of noncorrosive liquids.
4	Either indoor or outdoor use to provide a degree of protection against falling rain, splashing water, and hose-directed water; undamaged by the formation of ice on the enclosure.	13	Indoor use to provide a degree of protection against lint, dust seepage, external condensation, and spraying of water, oil, and noncorrosive liquids.

Table 6.1 revised December 5, 1986
©Copyright 1977, Underwriters Laboratories Inc.

Continued on next page.



*Namco Controls Corporation
Mayfield Village, OH 44143
(440) 460-1360 • FAX (440) 460-3800 • namcocontrols.com*

For technical assistance, call 1-800-NAMTECH

Electrical Considerations

Namco offers sensors that are suitable for direct connection to most common types of control systems. The most common types are listed below:

1. Relay Systems
2. Programmable Controllers
3. Custom Microprocessors
4. Output Devices (Solenoids)

When specifying a particular output type, at no time should the appropriate specifications of the particular sensor be exceeded or sensor failure may result.

A switch in a protective interlocking circuit should be used with at least one other device that will provide a redundant protective function, and the circuit should be so arranged that either device will interrupt the intended operation of the controlled equipment. (Proposed NEMA ICS 2-225.95 std.)

Namur Sensors

Namur refers to the standards committee of measurement and control of the chemical industry of Europe. Namco sensors comply with DIN 19234, and therefore are compatible with the Namur requirements.

This type of sensor contains only the "front end" of the typical proximity sensor coupled to an output transistor that will vary the current (not voltage) in proportion to the target distance (Fig. 10). This type of sensor is normally connected to an external amplifier which will provide the switch closure to an external control system. It is possible to interface these sensors to either custom external solid state relays or PLC (Programmable Logic Control) systems with the appropriate input card. When used with an approved intrinsically-safe control amplifier, Namur sensors can be used in hazardous areas. Please consult factory for application details.

When the target is not present, the sensor passes a small amount of current ($\geq 2.2\text{mA}$). The current decreases in a non-linear fashion as the target enters the sensing field. This action is similar to a variable resistor. (See Figure 10.)

RANGE vs. CURRENT (TYPICAL)

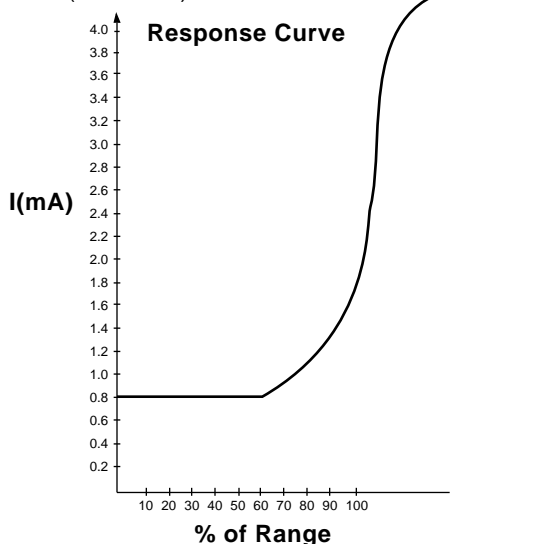
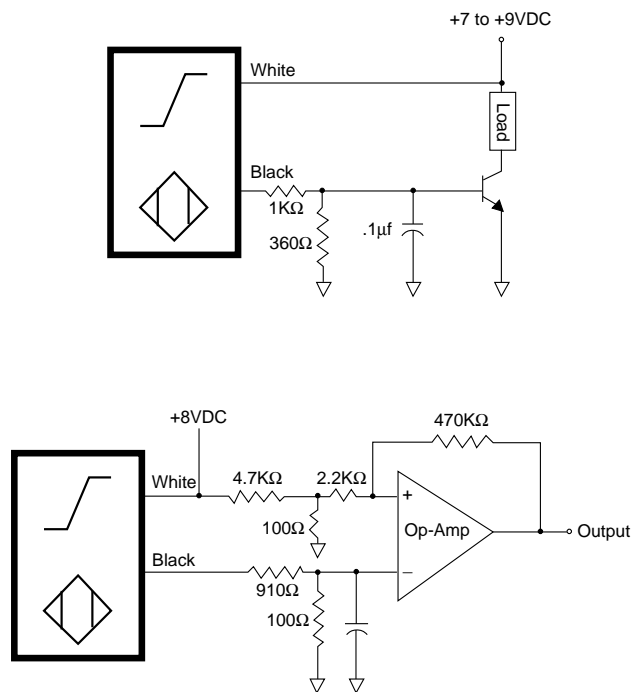

Figure 10

Suggested On/Off Output Circuits for NAMUR Sensors



DC Sensors

Available as either current sinking (NPN) or current sourcing (PNP), this type of sensor will provide the fastest output switching available.

The voltage range is typically 10-30 VDC with minimal drop across the output transistor for easy connection to programmable controllers. Most DC sensors include reverse polarity and short circuit protection as standard features.

Normally open output sensors are used in most applications. Normally closed output sensors can be made to order. Complimentary (one output "on," one output "off") output sensors (Fig. 11) can be used as a normally open and normally closed sensor at the same time. This convenient sensor can be used to replace a normally open sensor or a normally closed sensor. Simply hook up the desired output and either tape or cut off the load lead that is not being used.

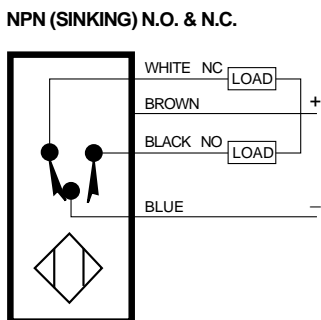

Figure 11

Dual output (NPN & PNP) sensors (Fig. 12) can have either output connected to a load, or each output connected to its own load, but not both to the same load. If the two outputs are each connected to separate loads as shown in Figure 12, the sum of the two load currents must not exceed the maximum load current of sensor (typically 200mA). This particular sensor output configuration is designed to minimize replacement inventories. It does not have complementary switching capabilities, i.e., both of the outputs switch either "on" or "off" at the same time.

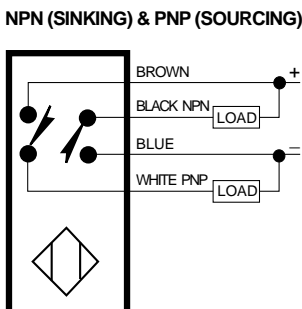

Figure 12

When connecting DC sensors to inductive loads, it is suggested that a diode be placed in the circuit to cancel any kickback that may damage the output of the sensor. (See Figure 13.)

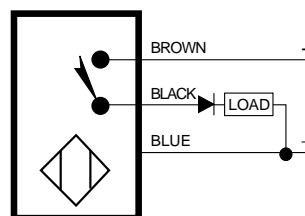

Figure 13

Series Connection:

AND circuits can be made by series connection of normally open output sensors.

NAND circuits can be made by series connection of normally closed output sensors.

The maximum number of sensors that may be wired in series is equal to the lowest number of the following two equations:

$$\# \text{ Sensors} = \frac{\text{Supply Voltage} - \text{Min. Operating Voltage of Load}}{\text{Voltage Drop Across Each Sensor}}$$

$$\# \text{ Sensors} = \frac{\text{Max. Sensor Output Current} - \text{Load Current}}{\text{No Load Current of Sensor}}$$

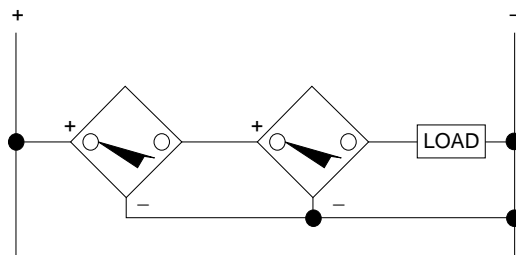

PNP Output shown - for NPN Output reverse V_{supply} and sensor polarities.

Continued on next page.



Namco Controls Corporation
Mayfield Village, OH 44143

(440) 460-1360 • FAX (440) 460-3800 • namcocontrols.com

For technical assistance, call 1-800-NAMTECH

In a long series string, it is possible to exceed the current handling capacity of the last or first sensor due to the sensor current requirements plus the load. This problem can be circumvented by alternating types; i.e., PNP, NPN, PNP, etc. Wiring the sensors in this manner will allow an infinite number to be wired in series.

Parallel Connection:

OR circuits can be made by parallel connection of normally open output sensors.

NOR circuits can be made by parallel connection of normally closed output sensors.

The maximum number of sensors that may be wired in parallel is equal to the current capacity of the voltage supply used.

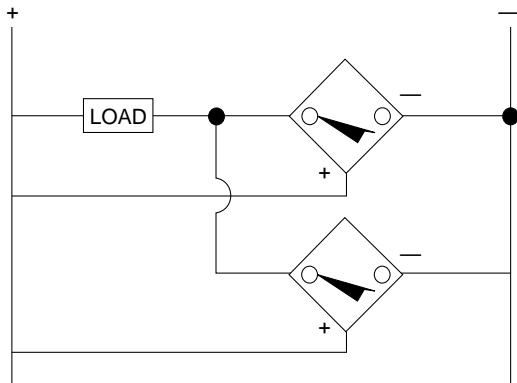

NPN Output shown - For PNP Output reverse V_{supply} and sensor polarities.

AC Sensors

AC sensors can also be connected to the same types of control systems as the DC types but are typically load powered. This configuration is a result of user demands for the high reliability of solid state sensors coupled to the requirement for minimal wiring.

In operation, the AC sensor will draw a small amount of current through the load with no target present. This current typically is less than 1.7mA allowing direct connection to programmable controller input cards with no shunt resistor required. This current must be allowed for when designing parallel logic circuits as the leakage currents may become large enough to actuate the load. This can be overcome by application of a properly sized shunt resistor.

Series Connection:

Note:

Connection of more than two AC sensors in series, is NOT recommended

AND circuits can be made by series connection of normally open output sensors.

NAND circuits can be made by series connection of normally closed output sensors.

The maximum number of sensors that may be wired in series:

$$\# \text{ Sensors} = \frac{\text{Supply Voltage} - \text{Min. Operating Voltage of Load}}{\text{Voltage Drop Across Each Sensor}}$$

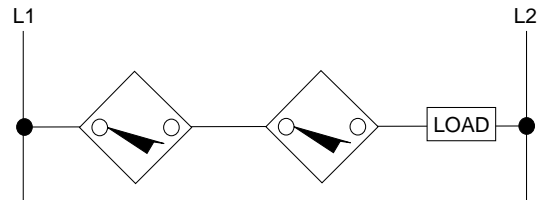

When a target is placed in the field and the sensor actuates, the amount of voltage available to the load will be reduced by approximately 8-10 volts. This value is critical in series circuits. Calculations for each series circuit must be made to ensure that enough voltage is available to actuate the load. The same problem exists when attempting to use a two-wire AC sensor at low AC voltages. For instance, if a 20-250 VAC sensor is used at 24VAC, the voltage available to the load will be between 14-18 VAC.

Parallel Connection:

OR circuits can be made by parallel connection of normally open output sensors.

NOR circuits can be made by parallel connection of normally closed output sensors.

The maximum number of sensors that may be wired in parallel is

$$\# \text{ Sensors} = \frac{\text{Holding Current of Load}}{\text{Leakage Current of Each Sensor}}$$

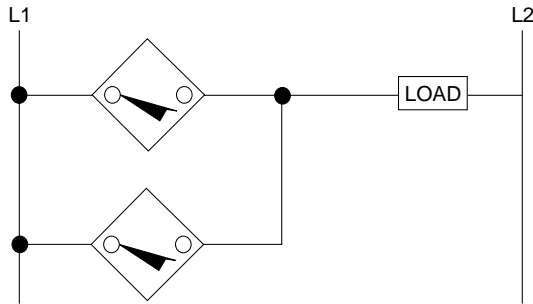

All AC sensors have switching speeds that are much lower than their DC counterparts. Typical switching speeds are 20 to 30 Hz.

Short circuit protection is a feature of many types of Namco sensors. This internal circuit will protect the sensor if the load inrush current exceeds 3 amperes. In the event of a large inrush current, the sensor will trip into "short circuit" mode. On standard ET/ER series sensors the LED does not illuminate. On WFI sensors both LEDs will flash, and the output current will be limited to approximately 2.5 mA. To restore the sensor it is necessary to remove power for approximately one second. The sensor will not function in SCP mode.

The short circuit protection feature is designed to protect the sensor and not the external circuit. The short circuit protection feature does not eliminate the need for branch circuit fusing.

Capacitive Sensors

Capacitive sensors are unique in that they will sense most materials including non-metallics. The actual sensing is performed by a circuit containing an oscillator, detector stage, and an output stage similar to the inductive type sensor. The differences are (1) the oscillator is not running when a target is not present, and (2) the sensing portion of the sensor is a special plate in the sensing surface of the sensor. This plate also has an opposing connection-to-earth ground through the detection circuit. When an object is placed near the sensing plate, the dielectric constant of the material will allow coupling from the sensing plate through the air-to-earth ground thus starting the oscillator. To provide adjustment for the various types of materials and their different dielectric constants, an adjustment potentiometer is typically provided.

This change in dielectric constant is a requirement for accurate sensing. If a material has a very low dielectric

constant, the sensor must be in very close proximity to the material being sensed. Conversely, a material with a high dielectric constant can be sensed at a greater distance.

The diagram below shows the reduction created by different materials.

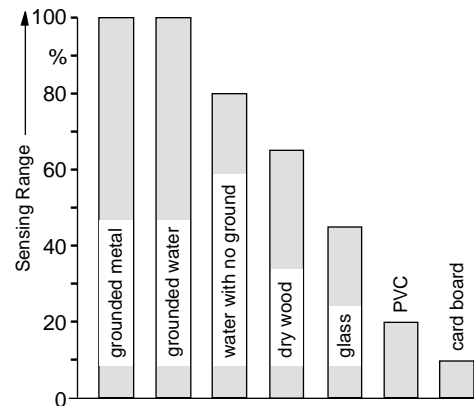

Materials with a high dielectric constant can be sensed through the walls of a container with a lower dielectric constant. Example: sensing water level in a boiler sight glass tube.

Application Cautions

1. The adjustment potentiometer is a non-linear device. Do not attempt to adjust the sensor beyond 2/3 of the maximum range obtained on a given material.
2. Never use a sensor with a metal housing in a damp environment. If the face of the metal housing sensor is splashed, the sensor will turn "On" and will not turn "Off" until the water is removed.
3. Because the capacitive sensor depends on coupling through the air, maximum range will be greater on hot, humid days. It may be possible to sense a particular material only on days when the humidity is high.
4. To determine if the material you wish to sense can be sensed reliably, Namco recommends actual testing. If this is not practical, consult our Applications Engineering Department.

NAMCO

Namco Controls Corporation

Mayfield Village, OH 44143

(440) 460-1360 • FAX (440) 460-3800 • namcocontrols.com

For technical assistance, call 1-800-NAMTECH

Notes:

1. These diagrams are valid for sensors with cables and connectors.
2. Sensors may or may not have ground connections or grounded housings. Refer to the specific connector or cable diagram for your particular sensor's model number to determine if it is grounded.
3. The markings on these wiring diagrams (L1, Load, etc.) are identical to those on the connector diagrams.
4. All switches are Normally Opened (N.O.) unless specifically marked Normally Closed (N.C.).
5. All switch outputs are Sourcing unless specifically marked Sink.

AC Wiring Diagrams

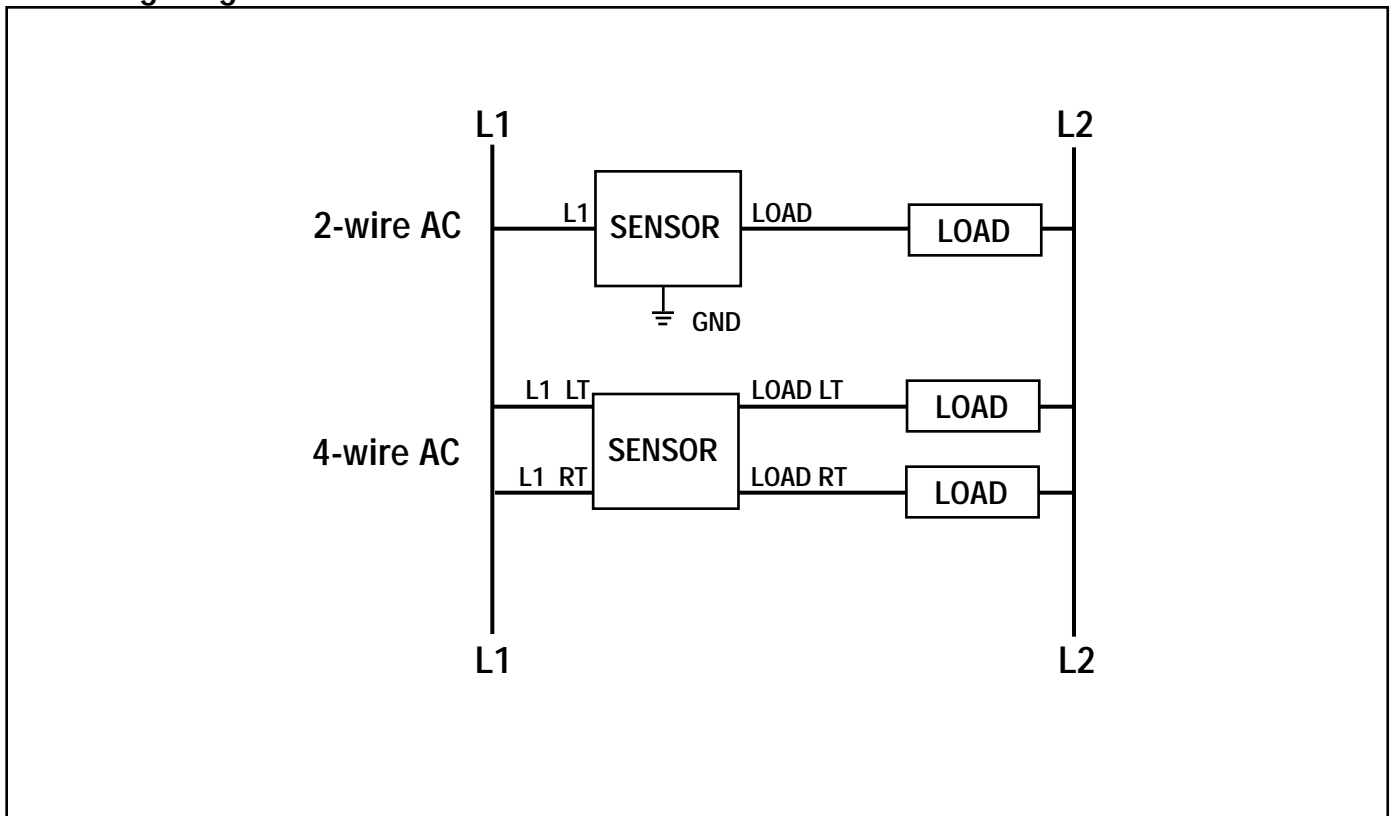

DC Wiring Diagrams

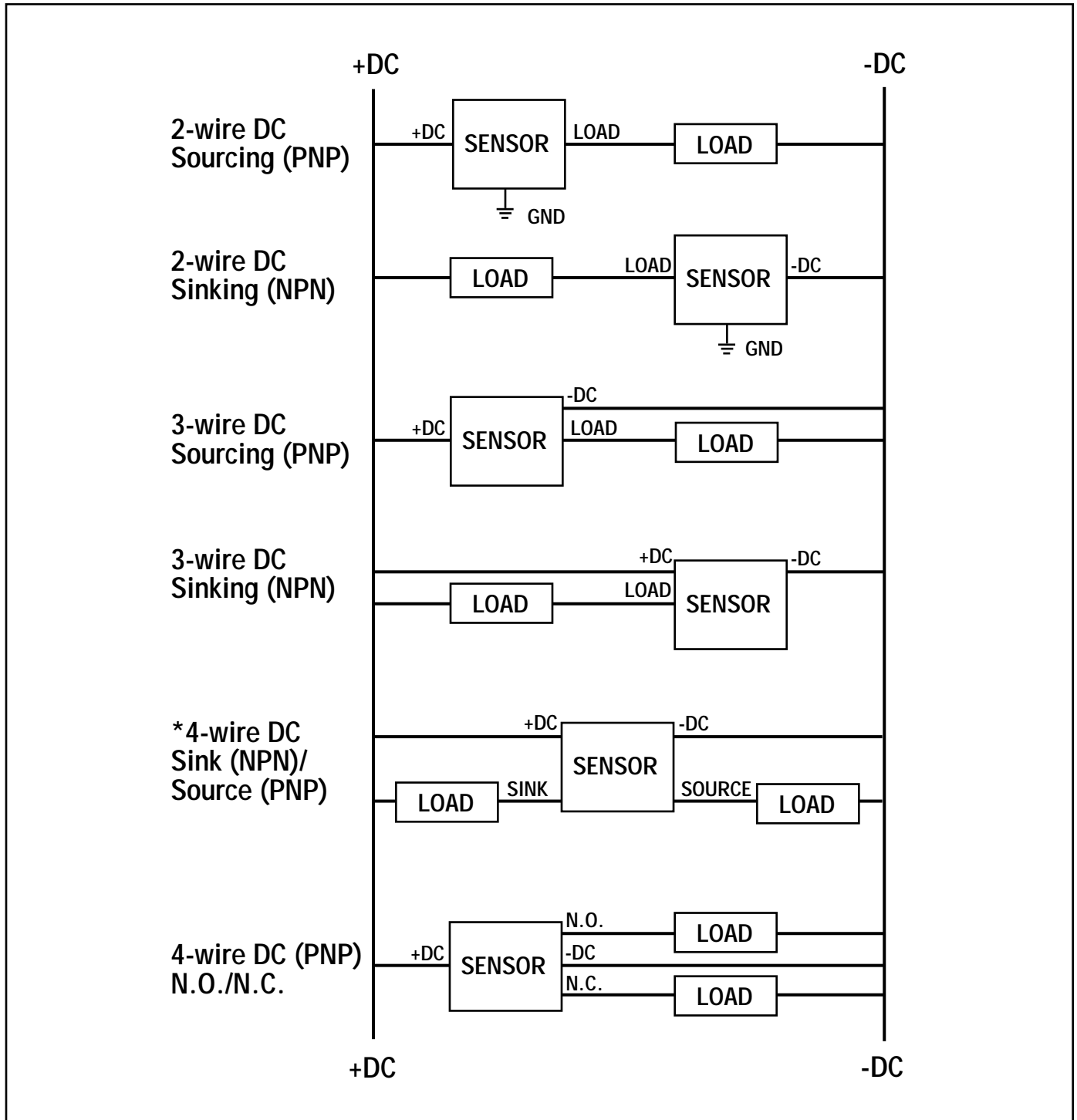

* Can be used as a single sink or source switch. When both outputs are used simultaneously, the sum of the load currents must not exceed maximum rating of sensor!

NAMCO

Namco Controls Corporation

Mayfield Village, OH 44143

(440) 460-1360 • FAX (440) 460-3800 • namcocontrols.com

For technical assistance, call 1-800-NAMTECH

Axial Approach: The approach path of a target whose center is the same as the centerline of the sensing field.

Capacitive Sensor: A solid state switch which senses a changing dielectric mass. Usually adjustable and able to sense most materials.

Complementary Output: A form "C" type output (normally open and normally closed) which changes state simultaneously when the sensor is actuated.

Current Consumption (No Load Current): This is the current consumption of a proximity sensor when the output transistor is in the off state. It is indicated at the maximum voltage rate.

Current Sinking (NPN): A negative switching output in which the load current passes through the load first, then "sinks" through the sensor.

Current Sourcing (PNP): A positive switching output in which the current for the load is "sourced" through the sensor.

Differential: The difference between the operating point and the release point of a sensor.

Dwell Time: The minimum time needed for a particular target to be in the sensing field for the output to be energized or de-energized.

Eddy Currents: Small circular currents induced on the surface of a metallic target by an inductive sensor.

Hysteresis: The difference between the operating point and the release point of a sensor. (See Fig. 1)

Inductive Sensor: A solid state switch which emits a small directional radio frequency field. When a metallic target enters the field, eddy current losses are created thereby loading the oscillator. If this loading exceeds an internal setpoint, the output of the sensor is energized.

Interference Protection: All Namco proximity sensors feature an interference protection circuitry. This feature assures that voltage peaks or release interference caused by relays does not destroy the proximity sensor.

Leakage Current: The current which flows through the load when the sensor is non-energized. Also called burden or residual current.

LED: Namco proximity sensors feature a light emitting diode to indicate with a red LED that the sensor output is conducting. WFI proximity sensors have a red LED to show unit is powered up and a green LED to indicate target is present.

Maximum Load Current: This is the maximum load at which a proximity sensor may be operated continuously.

Minimum Load Current: The minimum current necessary to assure proper output operation.

Operate Point: The point at which a target is sensed. (See Fig. 1)

Release Point: The point at which the sensor returns to a non-energized state as the target leaves the sensing field. (See Fig. 1)

Repeatability: The relative variation in effective operating distance measured repeatedly over an established period of time during which environmental and electrical conditions, (i.e., applied voltage, temperature, relative humidity, mounting, etc.) are held constant.

Response Time: The time delay between when the target

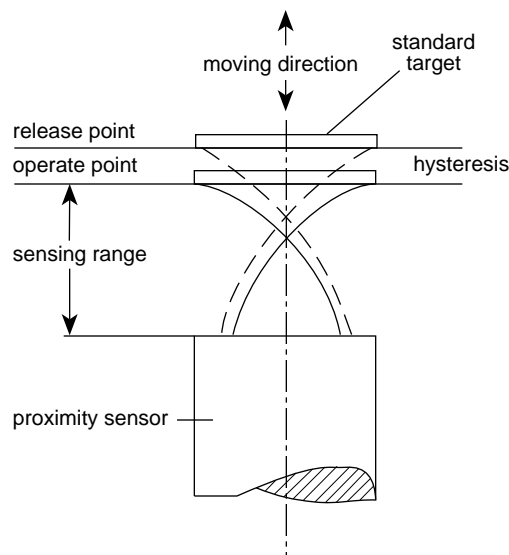

Figure 1

appears at the operate point and the output is energized.

Reverse Polarity Protection: Usually a diode inserted in one of the power leads of a D.C. Switch. This protects the internal circuitry if connections are accidentally reversed.

Sensing Range: The distance from the sensing face to a standard target at a specific temperature (usually 77°F). Most industrial type sensors usually will hold this range +/- 10% of rated sensing range. (See Fig. 1)

Shielded Sensor: A sensor which has a very directional sensing field. This allows the sensing face to be flush mounted in metal.

Short Circuit Protection (SCP): Internal circuitry which protects the sensor against accidental short circuits. SCP is not intended to protect other control circuit components or interconnecting wiring.

Standard Target: A mild steel plate 1mm thick, with sides equal to the diameter of the sensing face or 3 times rated sensing range, whichever is greater. (See Fig. 1)

Switching Frequency: The maximum speed at which a sensor will deliver discrete individual pulses as the target(s) enter and leave the sensing field. This value is always dependent on target size, distance from sensing face, speed of target and switch type. The catalog values given are obtained using a standard target.

Temperature Drift: The temperature drift indicates the change of the switching point caused by ambient temperature variations within the range of -13°F to +158°F. The temperature of the measuring plate does not influence the switching point. The switching point at -13°F to +158°F may vary up to 10% compared to the point measured at +68°F. (See Figure 2.)

Unshielded Sensor: A sensor which has an extended sensing range for its size. **Must not be flush mounted in metal unless a counterbore is cut such that the sensor is not influenced by the surrounding metal.**

Voltage Drop: The difference in voltage at the load measured with and without the sensor in a circuit. Must be taken into account when designing with any 2-wire device.

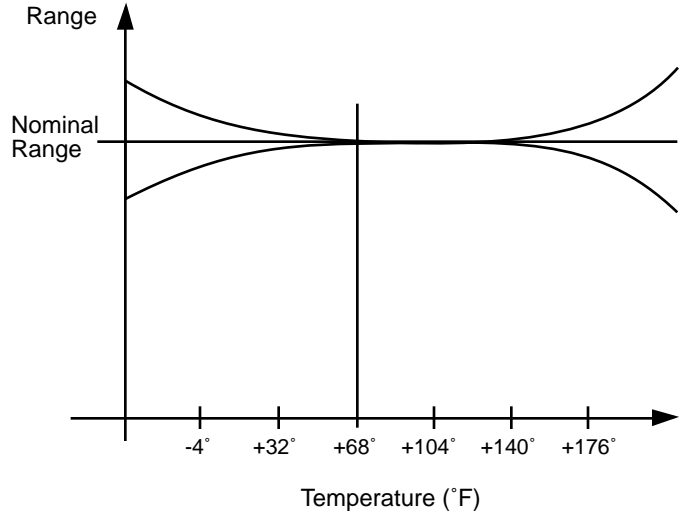

Figure 2



Namco Controls Corporation
Mayfield Village, OH 44143

(440) 460-1360 • FAX (440) 460-3800 • namcocontrols.com

For technical assistance, call 1-800-NAMTECH